



**Taylor Davis**  
...not just ANY packaging company!

# Product Specification Sheet

Product Category: **PLASTIC JARS**

Product Title: **JAR 225ML (65X80) T/E 8401203 - WHITE**

Product Code: **JB0225M001**

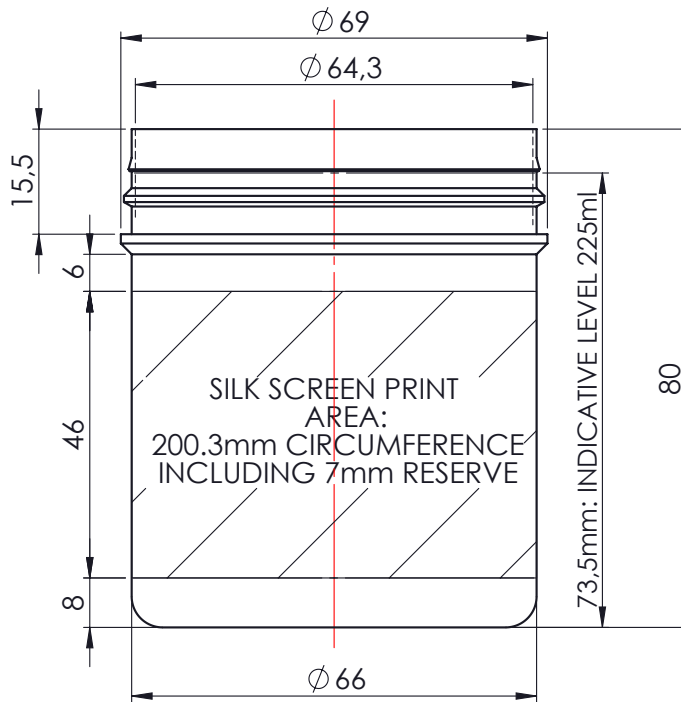

**DUPLICATA**

C	10/04/20	Update to Berry Title block			PHGO	PHGO
<b>Issue</b>	<b>Date</b>	<b>Modifications (see historic at back)</b>			<b>Modified</b>	<b>Checked</b>
		Designation: SnapLock Jar 65x80 225 ml			Drawn by: NIMA	Date: 26/04/01
					Checked by: DERO	Date: 10/11/16
		Raw material: PP	Brimfull capa.: 248±6 ml	Weight: 25±1g	Reference: 84012..	Drawing n°: WEB01_078
	A4	Scale: 1:1				
Standard for dimensions without tolerances: NFT 58 000 Normal class						
ALL REPRODUCTION OR COMMUNICATION TO THIRD PARTY IS STRICTLY FORBIDDEN WITHOUT BERRY WRITTEN AUTHORISATION						